

BALL CHECK VALVE

- PLASTIC VALVE WITH HIGH RESISTANCE TO BOTH INTERNAL AND EXTERNAL CORROSION CAUSED BY SEA WATER, VARIOUS ACIDS AND ALKALIS AND OTHER CHEMICALS.
- FLOW PASSAGE STRUCTURE WITH LOW FLUID RESISTANCE
- SMALL PARTS QUANTITY AND A SINGLE CONNECTION REDUCE EXTERNAL STRESS EFFECTS, ALLOWING HIGH FINISHING ACCURACY.
- LIGHTWEIGHT AND SMALL SIZE ALLOW INSTALLATION IN NARROW SPACES AND FACILITATE DISASSEMBLED CLEANING.

MANUAL

BASIC SPECIFICATIONS

VALVE TYPE ————— BALL CHECK VALVE

SIZE ————— 15 mm—100 mm (1/2 inch—4 inch)

BODY MATERIAL ————— **U-PVC** **C-PVC** **PP** **PVDF**

SEAL MATERIAL / SEAT ————— **EPDM** **FKM** etc.

CONNECTION / FLANGED — JIS5K, JIS10K, DIN, ANSI

SOCKET — JIS, DIN, ANSI

THREADED— Rc, Rp, NPT

	FLUID TEMPERATURE	MAXIMUM WORKING PRESSURE (NORMAL TEMPERATURE) (MPa)(psi)		CONNECTION METHOD		
		15 mm—50 mm	80mm—100mm	FLANGED	SOCKET	THREADED
U-PVC	0°C ~ 50°C	1.0 {10.2}	0.7 {7.1}	○	○	○
C-PVC	0°C ~ 90°C	1.0 {10.2}	0.7 {7.1}	○	○	○
PP	-20°C ~ 80°C	1.0 {10.2}	0.5 {5.1}	—	○	○
PVDF	-20°C ~ 100°C	1.0 {10.2}	0.7 {7.1}	—	○	○

NOTES The maximum working pressure is the value including the water hammer pressure. Be careful that the maximum working pressure is not exceeded during use.

* Concerning the allowable pressure for each temperature and material, see the technical documents at the end of this catalog. * For flanged type 15 - 50 mm with the body material of PP or PVDF, true union ball check valves can be used. For details, contact our sales office.



NOTES FOR USE

- Make sure during piping that the arrow direction of the valve body is aligned with the flow direction of the fluid.
- Do not use the valve in a line where the fluid flow is very turbulent. Oscillation of the ball may occur in the valve, causing breakage.
- Near pumps with unstable flow, use AV swing check valves.

PARTS LIST MANUAL

FLANGED

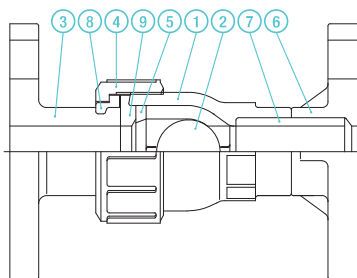

SOCKET

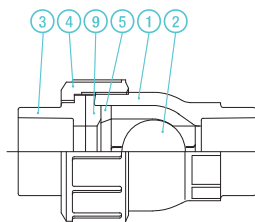

THREADED

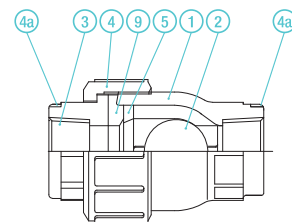

PART NO. / NAME	QTY	MATERIAL
① BODY	1	
② BALL	1	FLANGED U-PVC, C-PVC
③ END CONNECTOR	1	SOCKET U-PVC, C-PVC, PP, PVDF
④ UNION NUT	1	
⑤ STOP RING (A)	1	THREADED
⑥ TS FLANGE ⁽²⁾	1	U-PVC, C-PVC, PP, PVDF
⑦ PIPE ⁽²⁾	1	

PART NO. / NAME	QTY	MATERIAL
⑧ STOP RING (B) ⁽²⁾	1	PVDF
⑨ SEAT	1	EPDM, FKM, etc.
④a RING ⁽¹⁾	2	SUS304

NOTES (1) Used for 15 to 25 mm for C-PVC threaded type. (2) Used for flanged type.

PRODUCT MODEL CODE LIST
MANUAL

ACTUATION	TYPE	OPERATING SYSTEM	BODY MATERIAL	SEAL MATERIAL	CONNECTION	STANDARD	SIZE
V	BC	ZZ	*	*	*	*	***
V	BC	ZZ	U	E	S	J	015
MANUAL VALVE	BALL CHECK	NONE	U-PVC	EPDM	SOCKET	JIS	15mm
			C C-PVC	V FKM	N THREADED	1 JIS10K	?
			P PP		F FLANGED	5 JIS5K	100
			F PVDF		D DIN	A ANSI	100mm

- NOTES**
- PP and PVDF socket types are weld type.
 - PVDF socket type compatible with the JIS standard is not available.

- For 32 mm and 65 mm flanged types, individual service may be available. Contact us for more details.
- PP and PVDF flanged types are not produced.

MANUAL

BALL CHECK VALVE

TYPE—VBCZZ

CONNECTION / FLANGED, SOCKET, THREADED—JIS, DIN, ANSI SPIGOT—DIN

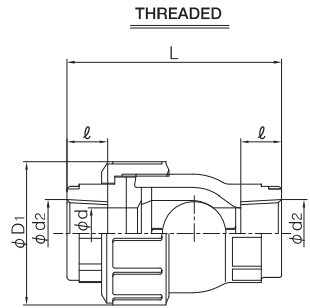
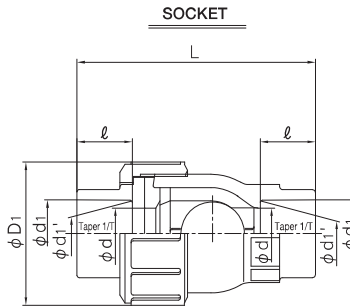
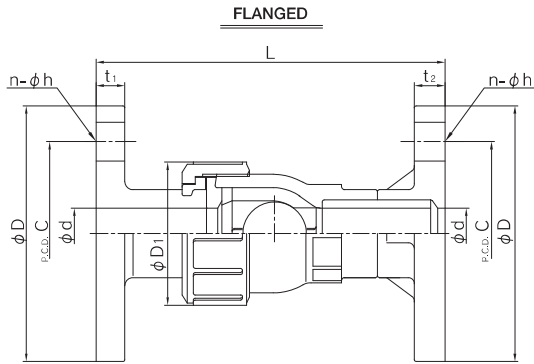

■ JIS (Unit: mm)

mm	d	D ₁	FLANGED														SOCKET								THREADED			
			JIS5K						JIS10K						U-PVC C-PVC				PP				JIS B 0203		L			
			D	C	n	h	t ₂	t ₁	D	C	n	h	t ₂	t ₁	L	t ₁	d ₁	ℓ	1/T	L	d ₁	d ₂	ℓ	L	d ₁	ℓ	U-PVC C-PVC	PVDF PP
15	15	48	80	60	4	12	9	9	95	70	4	15	14	14	131	12	22.11	20	1/34	89	21.2	20.2	22	93	Rc 1/2	15	80	78
20	20	60	85	65	4	12	10	10	100	75	4	15	15	14	156	14	26.13	24	1/34	106	26.2	25.2	23	104	Rc 1/4	17	95	92
25	25	70	95	75	4	12	10	10	125	90	4	19	15	16	169	14	32.16	27	1/34	117	33.0	32.0	25	113	Rc 1	20	105	102
40	40	96	120	95	4	15	12	12	140	105	4	19	16	16	214	16	48.21	37	1/37	162	47.0	46.0	28	144	Rc 1 1/2	25	141	137
50	51	106	130	105	4	15	14	14	155	120	4	19	20	20	244	16	60.25	42	1/37	189	59.0	58.0	28	162	Rc 2	28	164	160
80	78	152	180	145	4	19	14	-	185	150	8	19	22	22	310	18	89.60	64	1/49	277	88.0	86.0	35	219	Rc 3	35	222	216
100	100	210	200	165	8	19	16	-	210	175	8	19	22	22	397	18	114.70	84	1/56	376	113.0	111.0	45	298	Rc 4	45	308	301

■ DIN (Unit: mm)

mm	d	D ₁	SOCKET								THREADED				SPIGOT				
			U-PVC C-PVC				PP PVDF				DIN 2999				DIN 3442				
			DIN 8063		L		DIN 16962		L		d ₁	ℓ	L		d _s	t ₁		ℓ	L
15	15	48	20	16	81	19.50	19.30	14	78	Rp 1/2	15	80	78	20	2.5	1.9	19.0	100	
20	20	60	25	19	96	24.50	24.30	16	90	Rp 1/4	17	95	92	25	2.7	1.9	19.0	110	
25	25	70	32	22	107	31.50	31.30	18	99	Rp 1	20	105	102	32	3.0	2.4	19.0	116	
40	40	96	50	31	150	49.45	49.20	23	135	Rp 1 1/2	25	141	137	50	4.6	2.9	19.0	142	
50	51	106	63	38	181	62.50	62.10	27	160	Rp 2	28	164	160	63	5.8	3.0	19.0	157	
80	78	152	90	51	248	89.20	88.85	35	217	Rp 3	35	222	216	90	8.2	4.3	38.0	256	
100	100	210	110	61	330	109.05	108.65	41	291	Rp 4	45	308	301	110	10.0	5.3	44.5	333	

■ ANSI (Unit: inch)

inch	mm	d	D ₁	FLANGED								SOCKET								THREADED				
				ANSI CLASS 150				L				U-PVC C-PVC				PVDF PP				ANSI/ASME B 1.20.1				
				D	C	n	h	U-PVC	t ₁	t ₂	d ₁	d ₂	ℓ	L	d ₁	d ₂	ℓ	L	d ₁	ℓ	U-PVC C-PVC	PVDF PP		
1/2	15	0.59	1.89	3.50	2.38	4	0.63	5.16	0.47	0.55	0.848	0.836	0.688	3.35	0.825	-	0.874	3.82	1/2-14NPT	0.59	3.15	3.07		
3/4	20	0.79	2.36	3.86	2.75	4	0.63	6.14	0.55	0.59	1.058	1.046	0.719	3.74	1.030	-	1.000	4.41	3/4-14NPT	0.67	3.74	3.62		
1	25	0.98	2.76	4.25	3.12	4	0.63	6.65	0.55	0.59	1.325	1.310	0.875	4.33	1.300	-	1.126	4.88	1-11 1/2 NPT	0.79	4.13	4.02		
1 1/2	40	1.57	3.78	5.00	3.88	4	0.63	8.43	0.63	0.63	1.912	1.894	1.094	5.71	1.890	-	1.374	5.79	1 1/2-11 1/2 NPT	0.98	5.55	5.39		
2	50	2.01	4.17	5.98	4.75	4	0.75	9.61	0.63	0.79	2.387	2.369	1.156	6.50	2.360	-	1.500	6.89	2-11 1/2 NPT	1.10	6.46	6.30		
3	80	3.07	5.98	7.52	6.00	4	0.75	12.20	0.71	0.87	3.516	3.492	1.875	9.57	3.480	-	1.874	9.57	3-8NPT	1.38	8.74	8.50		
4	100	3.94	8.27	9.02	7.50	8	0.75	15.63	0.71	0.87	4.518	4.491	2.000	12.20	4.480	-	2.252	12.68	4-8NPT	1.77	12.13	11.85		

TRUE UNION BALL CHECK VALVE

- THE VALVE PARTS CAN BE REMOVED WITHOUT DISCONNECTING THE PIPES, BY LOOSENING THE UNIONS ON BOTH SIDES

BASIC SPECIFICATIONS

VALVE TYPE ————— TRUE UNION BALL CHECK VALVE

SIZE ————— 15 mm—50 mm (1/2 inch—2 inch)

BODY MATERIAL ——— **U-PVC** **C-PVC** **PP** **PVDF**

SEAL MATERIAL / SEAT — **EPDM** **FKM** etc.

CONNECTION / FLANGED — DIN, ANSI

SOCKET — DIN, ANSI

THREADED— Rp, NPT

SPIGOT — DIN

	FLUID TEMPERATURE	MAXIMUM WORKING PRESSURE (NORMAL TEMPERATURE) MPa(kgf/cm ²)	CONNECTION METHOD		
			FLANGED	SOCKET	THREADED
PVDF	-20°C ~ 100°C	1.0 {10.2}	○	○	○
PP	-20°C ~ 80°C	1.0 {10.2}	○	○	○

NOTES The maximum working pressure is the value including the water hammer pressure. Be careful that the maximum working pressure is not exceeded during use.
* Concerning the allowable pressure for each temperature and material, see the technical documents at the end of this catalog.

MANUAL



PARTS LIST **MANUAL**

FLANGED

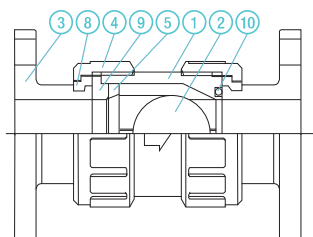

SOCKET

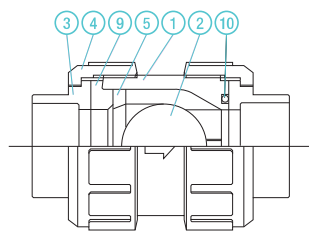

THREADED

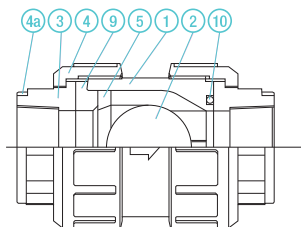

SPIGOT

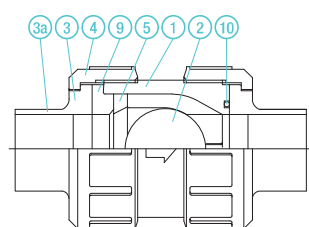

PART NO. / NAME	QTY	MATERIAL
① BODY	1	
② BALL	1	
③ END CONNECTOR	2	U-PVC, C-PVC, PP, PVDF
④ UNION NUT	2	
⑤ STOP RING (A)	1	

PART NO. / NAME	QTY	MATERIAL
⑧ STOP RING (B) ⁽²⁾	2	PVDF
⑨ SEAT	1	EPDM, FKM, etc.
⑩ O-RING	1	EPDM, FKM, etc.
④a RING ⁽¹⁾	2	SUS304

NOTES (1) Used for 15 to 25 mm for C-PVC threaded type. (2) Used for flanged type.

PRODUCT MODEL CODE LIST
[MANUAL](#)

ACTUATION	TYPE	OPERATING SYSTEM	BODY MATERIAL	SEAL MATERIAL	CONNECTION	STANDARD	SIZE
V	TC	ZZ	*	*	*	*	***
⋮	⋮	⋮	⋮	⋮	⋮	⋮	⋮
V MANUAL VALVE	TC TRUE UNION BALL CHECK	ZZ NONE	U U-PVC C C-PVC P PP F PVDF	E EPDM V FKM	S SOCKET N THREADED F FLANGED P SPIGOT	D DIN A ANSI	015 15mm ? 050 50mm

[MANUAL](#)

TRUE UNION BALL CHECK VALVE

TYPE—VTCZ
 CONNECTION / FLANGED, SOCKET, THREADED, SPIGOT—DIN

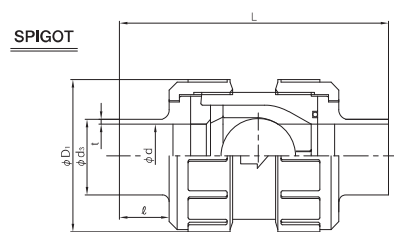
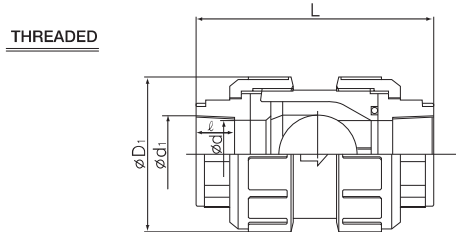
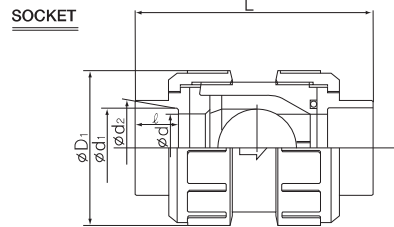
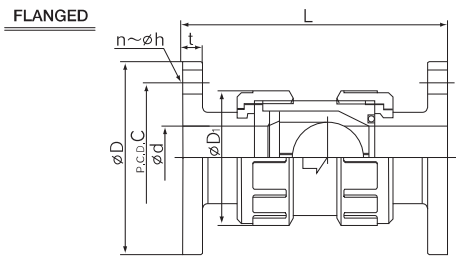

■ DIN (Unit: mm)

mm	d	D ₁	FLANGED							SOCKET						
			DIN PN10				L			U-PVC C-PVC			PVDF PP			
			D	C	n	h	U-PVC C-PVC	PP	t	DIN 8063		DIN 16962		L		
15	15	48	95	65	4	14	130	128	12	d ₁	ℓ	L	d ₁	d ₂	ℓ	L
20	20	60	105	75	4	14	155	154	14	20	16	84	19.50	19.30	14	79
25	25	70	115	85	4	14	165	163	14	25	19	100	24.50	24.30	16	93
40	40	96	150	110	4	18	192	190	16	32	22	113	31.50	31.30	18	103
50	51	106	165	125	4	18	214	211	16	50	31	158	49.45	49.20	23	141
										63	38	190	62.50	62.10	27	167

mm	d _s	SPIGOT									THREADED			
		DIN 3442						DIN 2999			L			
		U-PVC			PP			PVDF			d ₁	ℓ	U-PVC C-PVC	PVDF PP
15	20	t	ℓ	L	t	ℓ	L	t	ℓ	L	Rp 1/2	15	86	83
20	25	2.5	16	113	2.5	19	102	1.9	19	102	Rp 3/4	17	103	98
25	32	2.5	18.5	127	2.7	19	110	1.9	19	110	Rp 1	20	113	109
40	50	3.5	22	132	3	19	118	2.4	19	118	Rp 1 1/2	25	151	147
50	63	5	31	174	4.6	19	145	2.9	19	145	Rp 2	28	177	171
		6.5	37.5	204	5.8	19	164	3	19	164				

ANSI (Unit: inch)

inch	mm	d	D ₁	FLANGED							SOCKET						THREADED					
				ANSI Class 150				L			U-PVC C-PVC			PVDF PP			ANSI/ASME B 1.20.1		L			
				D	C	n	h	U-PVC C-PVC	PP	t ₁	ASTM SCH40		L	d ₁	d ₁ '	ℓ	L	d ₁	ℓ	U-PVC C-PVC	PP PVDF	
1/2	15	0.59	1.89	3.50	2.38	4	0.62	5.12	5.04	0.47	d ₁	d ₂	ℓ	L	d ₁	d ₁ '	ℓ	L	1/2-14NPT	0.59	3.39	3.27
3/4	20	0.79	2.36	3.88	2.75	4	0.62	6.10	6.06	0.55	1.058	1.046	0.719	3.86	1.041	-	1.000	4.37	3/4-14NPT	0.67	4.06	3.86
1	25	0.98	2.76	4.25	3.12	4	0.62	6.50	6.42	0.55	1.325	1.310	0.875	4.37	1.305	-	0.827	4.29	1-11 1/2NPT	0.79	4.45	4.29
1 1/2	40	1.57	3.78	5.00	3.88	4	0.62	7.56	7.48	0.63	1.912	1.894	1.094	5.94	1.889	-	1.260	6.22	1 1/2-11 1/2NPT	0.98	5.94	5.79
2	50	2.01	4.17	6.00	4.75	4	0.75	8.43	8.31	0.63	2.387	2.369	1.156	6.77	2.364	-	1.260	6.93	2-11 1/2NPT	1.10	6.97	6.73

BALL FOOT VALVE

- INTEGRAL MOLDING WITH SCREEN INCREASES STRENGTH AT CONNECTION AREA.
- FLOW PASSAGE STRUCTURE WITH LOW FLUID RESISTANCE
- SMALL PARTS QUANTITY AND A SINGLE CONNECTION REDUCE EXTERNAL STRESS EFFECTS, ALLOWING HIGH FINISHING ACCURACY.
- LIGHTWEIGHT AND SMALL SIZE ALLOW INSTALLATION IN NARROW SPACES AND FACILITATE DISASSEMBLED CLEANING.

BASIC SPECIFICATIONS

VALVE TYPE ————— BALL FOOT VALVE

SIZE ————— 15 mm—100 mm (1/2 inch—4 inch)

BODY MATERIAL ————— **U-PVC** **C-PVC** **PP** **PVDF**

SEAL MATERIAL / SEAT ————— **EPDM** **FKM** etc.

CONNECTION / FLANGED — JIS5K, JIS10K, DIN, ANSI

SOCKET — JIS, DIN, ANSI

THREADED— Rc, Rp, NPT

	FLUID TEMPERATURE	MAXIMUM WORKING PRESSURE (NORMAL TEMPERATURE) MPa(kgf/cm ²)		CONNECTION METHOD		
		15 mm—50 mm	80mm—100mm	FLANGED	SOCKET	THREADED
U-PVC	0°C ~ 50°C	1.0 {10.2}	0.7 {7.1}	○	○	○
C-PVC	0°C ~ 90°C	1.0 {10.2}	0.7 {7.1}	○	○	○
PP	-20°C ~ 80°C	1.0 {10.2}	0.5 {5.1}	—	○	○
PVDF	-20°C ~ 100°C	1.0 {10.2}	0.7 {7.1}	—	○	○

NOTES The maximum working pressure is the value including the water hammer pressure. Be careful that the maximum working pressure is not exceeded during use.

* Concerning the allowable pressure for each temperature and material, see the technical documents at the end of this catalog.

MANUAL



PARTS LIST [MANUAL](#)

FLANGED

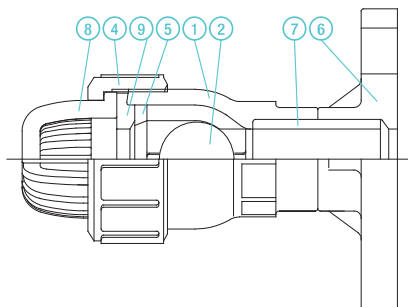

SOCKET

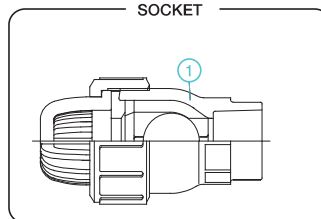

THREADED

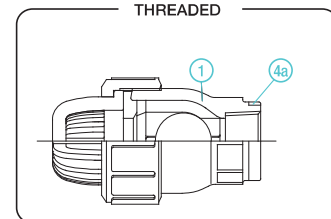

PART NO. / NAME	QTY	MATERIAL
① BODY	1	
② BALL	1	FLANGED U-PVC, C-PVC
④ UNION NUT	1	SOCKET U-PVC, C-PVC, PP, PVDF
⑤ STOP RING (A)	1	
⑥ TS FLANGE	1	THREADED U-PVC, C-PVC, PP, PVDF
⑦ PIPE	1	
⑧ SCREEN	1	

PART NO. / NAME	QTY	MATERIAL
⑨ SEAT	1	EPDM, FKM, etc.
④a RING ⁽¹⁾	1	SUS304

NOTES (1) Used for 15 to 25 mm for body material of C-PVC and connection of threaded type. (2) Used for flanged type. (3) PP flanged type is not produced.

PRODUCT MODEL CODE LIST
MANUAL

ACTUATION	TYPE	OPERATING SYSTEM	BODY MATERIAL	SEAL MATERIAL	CONNECTION	STANDARD	SIZE
V	FT	ZZ	*	*	*	*	***
⋮	⋮	⋮	⋮	⋮	⋮	⋮	⋮
V MANUAL VALVE	FT BALL FOOT	ZZ NONE	U U-PVC C C-PVC P PP F PVDF	E EPDM V FKM	S SOCKET N THREADED F FLANGED	J JIS 1 JIS10K 5 JIS5K D DIN A ANSI	015 15mm ? 100 100mm

- NOTES**
- PP and PVDF socket types are weld type.
 - PVDF sockets are of DIN type only.
 - For 32 mm and 65 mm flanged types, individual service may be available. Contact us for more details.
 - PP and PVDF flanged types are not produced.

MANUAL

BALL FOOT VALVE

TYPE—VFTZZ

CONNECTION / FLANGED, SOCKET—JIS, DIN, ANSI THREADED—Rc, Rp, NPT

FLANGED

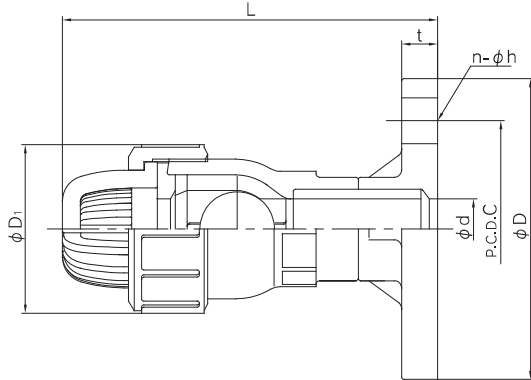

SOCKET

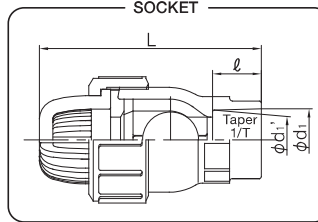

THREADED

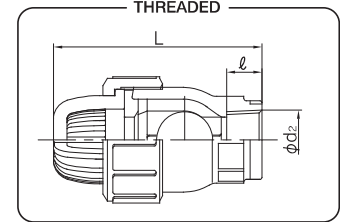

■ JIS (Unit: mm)

mm	D ₁	d	FLANGED											SOCKET				THREADED							
			JIS5K				JIS 10K				L			U-PVC C-PVC				PP				d ₂	ℓ	L	
			D	C	n	h	D	C	n	h	U-PVC	C-PVC	t	d ₁	ℓ	1/T	L	d ₁	d ₂	ℓ	L			U-PVC C-PVC	PVDF PP
15	48	18	80	60	4	12	95	70	4	15	130	130	14	22.11	20	1/34	95	21.2	20.2	22	97	Rc 1/2	15	90	88
20	60	22	85	65	4	12	100	75	4	15	150	150	15	26.13	24	1/34	110	26.2	25.2	23	108	Rc 1/4	17	103	101
25	70	25	95	75	4	12	125	90	4	19	167	171	15	32.16	27	1/34	121	33.0	32.0	25	118	Rc 1	20	114	111
40	96	41	120	95	4	15	140	105	4	19	246	250	16	48.21	37	1/37	184	47.0	46.0	28	174	Rc 1 1/2	25	172	169
50	106	52	130	105	4	15	155	120	4	19	274	277	20	60.25	42	1/37	203	59.0	58.0	28	188	Rc 2	28	189	185
80	152	78	180	145	4	19	185	150	8	19	396	409	22	89.60	64	1/49	323	88.0	86.0	35	293	Rc 3	35	294	289
100	210	100	200	165	8	19	210	175	8	19	506	518	22	114.70	84	1/56	413	113.0	111.0	45	372	Rc 4	45	374	367

■ DIN (Unit: mm)

mm	SOCKET								THREADED			
	U-PVC C-PVC				PP PVDF				d ₂	ℓ	L	
	d ₁	ℓ	L	d ₁	d ₁ '	ℓ	L	U-PVC C-PVC			PVDF PP	
15	20	16	91	19.50	19.30	14.5	89	Rp 1/2	15	90	88	
20	25	19	105	24.50	24.30	16	101	Rp 3/4	17	103	101	
25	32	22	116	31.50	31.30	18	111	Rp 1	20	114	111	
40	50	31	178	49.45	49.20	23.5	169	Rp 1 1/2	25	172	169	
50	63	38	199	62.50	62.10	27.5	187	Rp 2	28	189	184	
80	90	51	310	89.20	88.85	35.5	293	Rp 3	35	294	288	
100	110	61	390	109.05	108.65	41.5	368	Rp 4	45	374	366	

■ ANSI (Unit: inch)

inch	mm	d	D ₁	FLANGED							SOCKET				THREADED			
				D	C	n	h	L		t	d ₁	d ₁ '	ℓ	L	d ₂	ℓ	L	
				U-PVC	C-PVC	U-PVC	C-PVC	d ₁	d ₁ '	ℓ	L	U-PVC C-PVC	PVDF PP					
1/2	15	0.71	1.89	3.50	2.38	4	0.62	5.55	0.47	0.848	0.836	0.69	3.74	1/2-14NPT	0.59	3.54	3.46	
3/4	20	0.87	2.36	3.86	2.76	4	0.62	6.42	0.51	1.058	1.046	0.72	4.17	3/4-14NPT	0.67	4.06	3.98	
1	25	0.98	2.76	4.25	3.13	4	0.62	6.73	0.59	1.325	1.310	0.87	4.76	1-11 1/2 NPT	0.79	4.49	4.37	
1 1/2	40	1.61	3.78	5.00	3.88	4	0.62	9.80	0.63	1.912	1.894	1.09	6.97	1 1/2-11 1/2 NPT	0.98	6.77	6.65	
2	50	2.05	4.17	5.98	4.74	4	0.75	10.91	0.79	2.387	2.369	1.16	7.60	2-11 1/2 NPT	1.10	7.44	7.24	
3	80	3.07	5.98	7.52	6.00	4	0.75	16.10	0.87	3.516	3.492	1.87	12.09	3-8NPT	1.38	11.57	11.34	
4	100	3.94	8.27	9.02	7.50	8	0.75	20.41	0.87	4.518	4.491	2.00	14.96	4-8NPT	1.77	14.72	14.41	